



SOLUTIONS FOR **WASTE MANAGEMENT**

 MADE IN ITALY

 **REGGIANA
RIDUTTORI**
PLANETARY REDUCTION **GEARS**



OUR DRIVES

FOR SUSTAINABILITY

Today the environmental issue is important and urgent: with 50 years of engineering experience, **Reggiana Riduttori** - now part of Interpump Group S.p.a - provides complete transmission solutions for **materials and waste water recycling plants**. Our offer includes **planetary, rotation, winch, shaft and bevel gearboxes** to cover all application needs, optimizing plant performance and really reducing environmental impact and operating costs.

These solutions are developed with a high degree of customization, to adapt perfectly to the customer's needs.



*Oggi il tema ambientale è importante ed urgente: con 50 anni di esperienza ingegneristica, **Reggiana Riduttori** - ora parte di Interpump Group S.p.a - fornisce soluzioni complete per la trasmissione di potenza negli **impianti di riciclo materiali e acque reflue**.*

*La nostra offerta comprende **riduttori epicicloidali, per rotazione, per argano, lineari e angolari** per coprire tutte le esigenze applicative, ottimizzando le prestazioni degli impianti e riducendone realmente impatto ambientale e costi di gestione.*

Queste soluzioni sono sviluppate con un alto grado di personalizzazione, per adattarsi perfettamente alle esigenze del cliente.

ATEX & DNV CERTIFICATIONS

100% MANUFACTURED IN ITALY

TURNKEY SOLUTIONS





COMPLETE RANGE
FOR SHREDDING, CONVEYING,
SCREENING, CLARIFYING



■ RR/RA
T_{2max} Nm=1,200-10,000,000
Ratio=3.4-5061
 Modular planetary reduction gears.



■ RRTD/RRWD
T_{2max} Nm=1,000-50,000
Ratio=5-179
 Compact planetary drives.

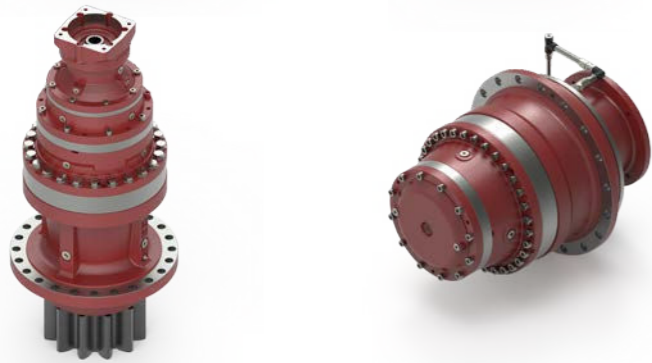

■ RR...FF/RR...W
T_{2max} Nm=1.200-230.000
Ratio=3,4-2500
 Slewing drives.
T_{2max} Nm=10,000-1,100,000
Ratio=12-860
 Winch drives.

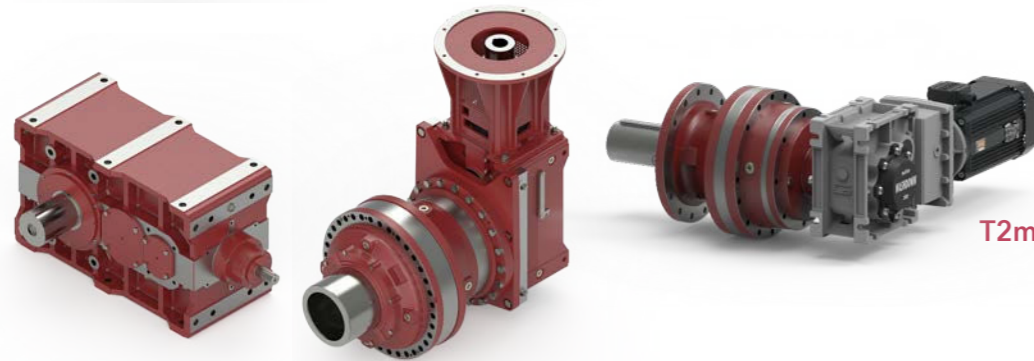

■ P/RH/RV
& Combined
T_{2max} Nm=2.500-4.300.000
Ratio=1,12-5061
 Helical and bevel helical
 line, combined units.



Electric motor arrangement available.



TRANSMISSIONS FOR THE WASTE MANAGEMENT



RECYCLING PLANT

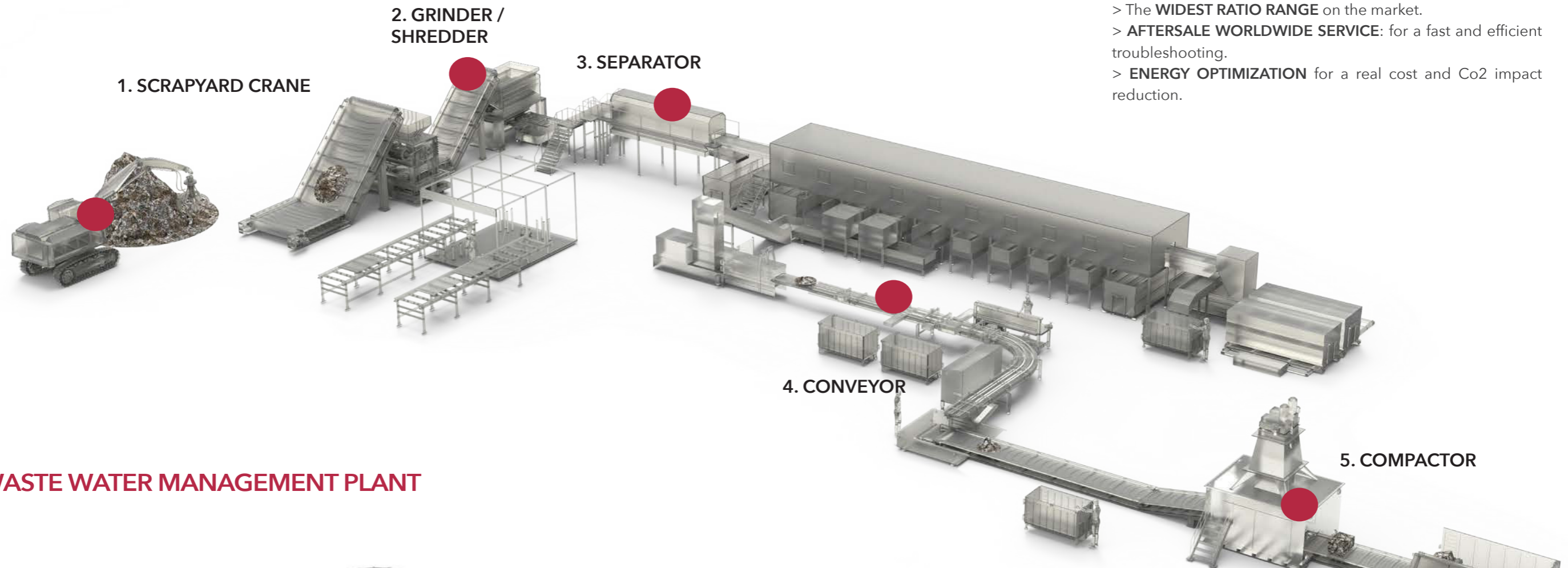

TURNKEY SOLUTION

- > The **WIDEST RATIO RANGE** on the market.
- > **AFTERSALE WORLDWIDE SERVICE:** for a fast and efficient troubleshooting.
- > **ENERGY OPTIMIZATION** for a real cost and Co2 impact reduction.

WASTE WATER MANAGEMENT PLANT

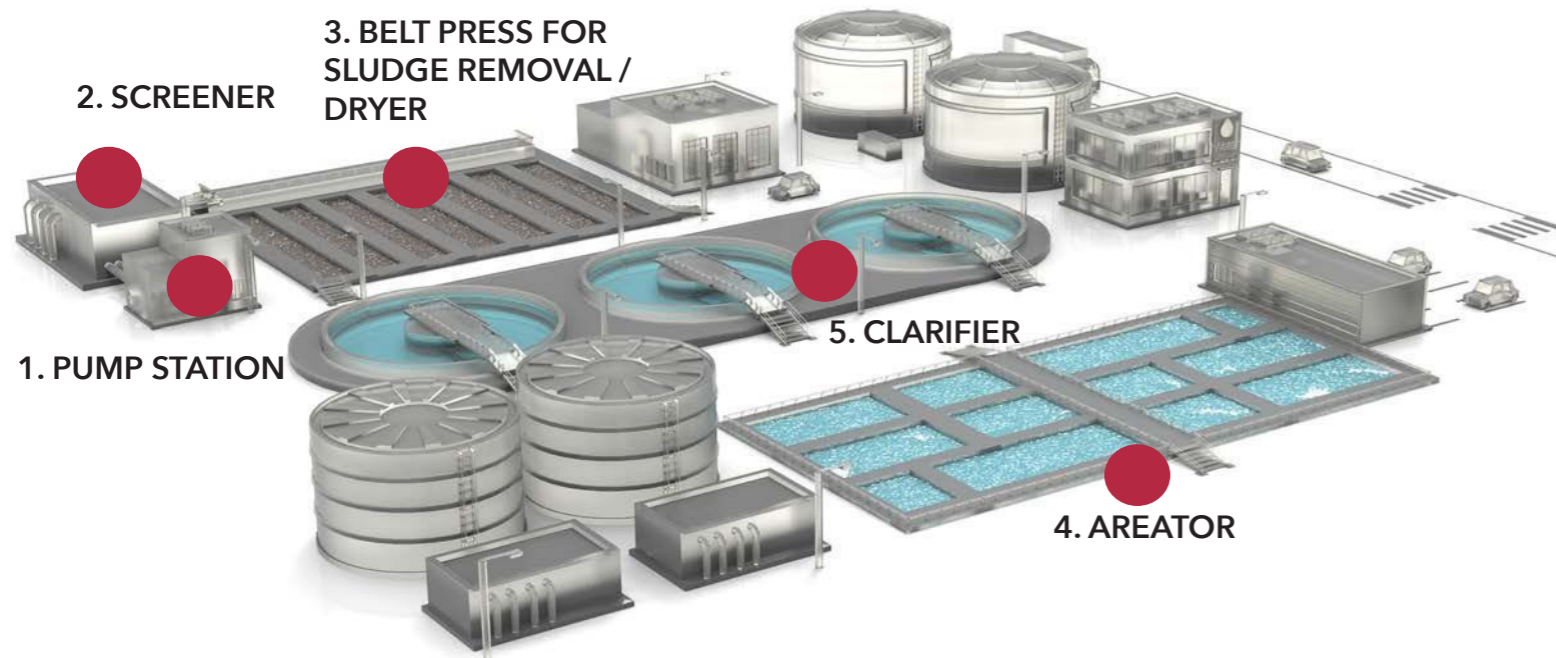

* the electric solution reduce power consumption by around 30% compared to hydraulic one, offering the same performance quality and durability.
More information available on Edrives brochure.

SHREDDING SPECIALISTS



KEY FEATURES FOR SHREDDERS

- > **COMPACTNESS.**
- > **HIGH TORQUE RESISTANCE:** to process all kind of materials.
- > **RELIABLE AND EFFICIENT:** ready to work 24/7.
- > **HYDRAULIC OR ELECTRIC** input.
- > Extreme possibility of **CUSTOMIZATION.**
- > **LONG OPERATING LIFE.**

**LOW
WEIGHT**

**HIGH
SHREDDING
PAYLOAD**



CRUSHER

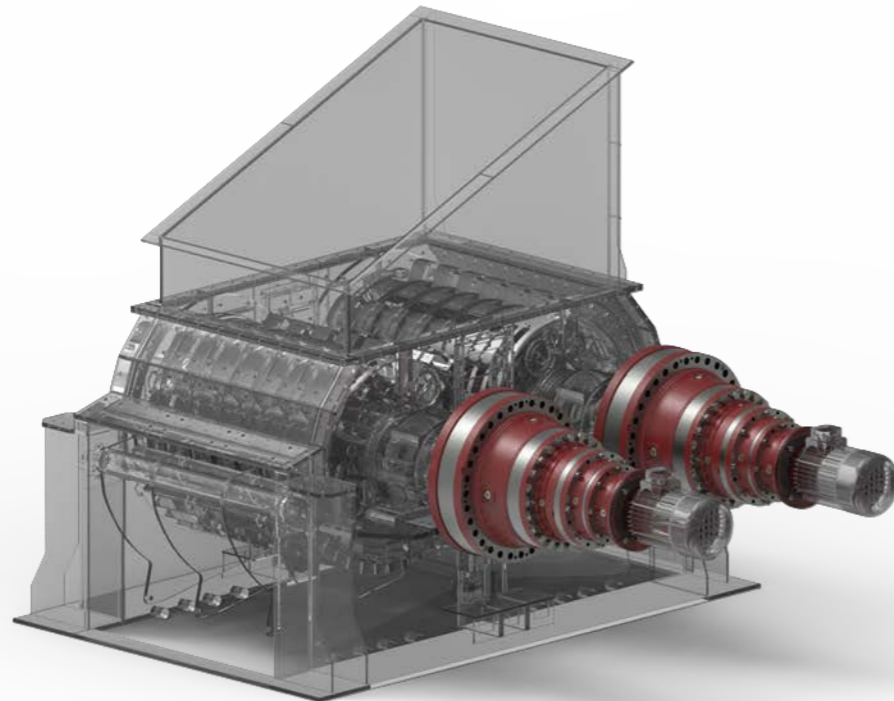

MOBILE SHREDDER

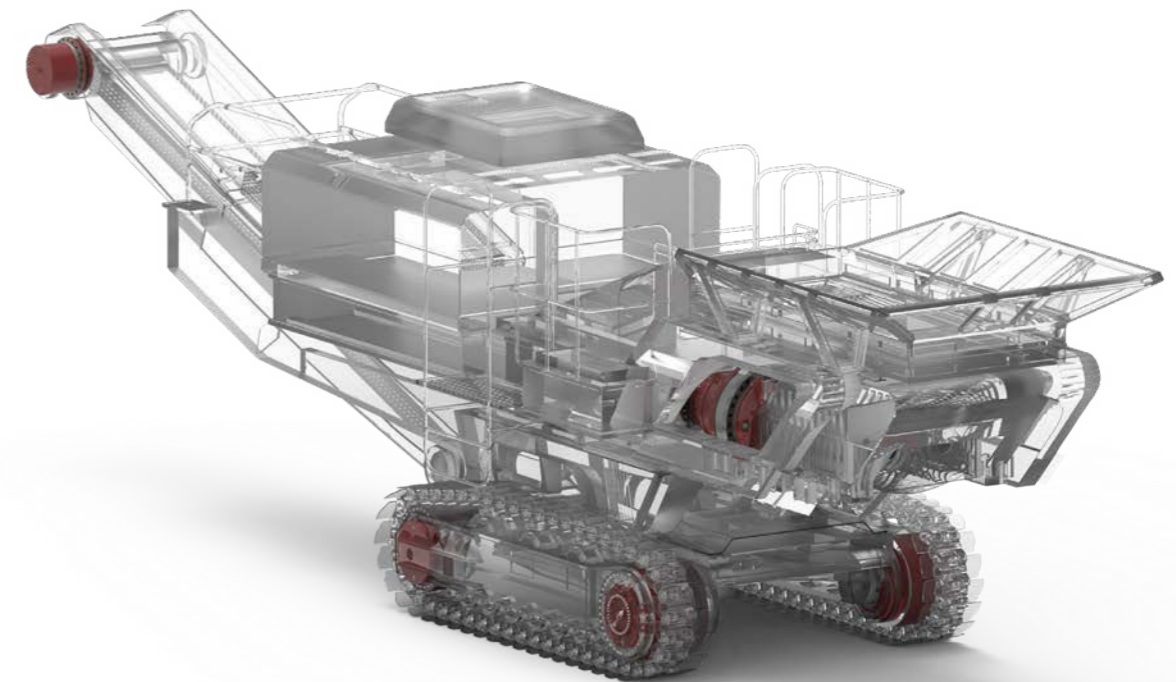

STATIONARY SHREDDER

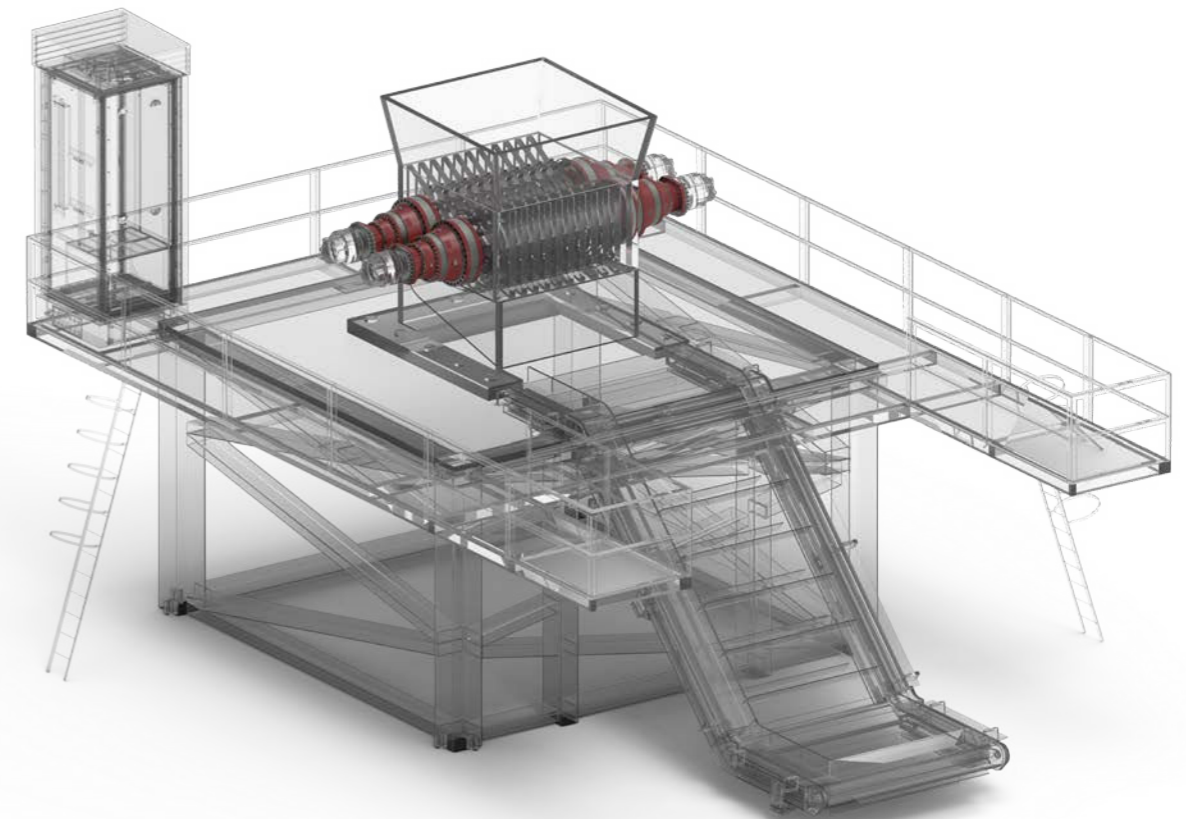



WASTE WATER TREATMENT

CLARIFIER

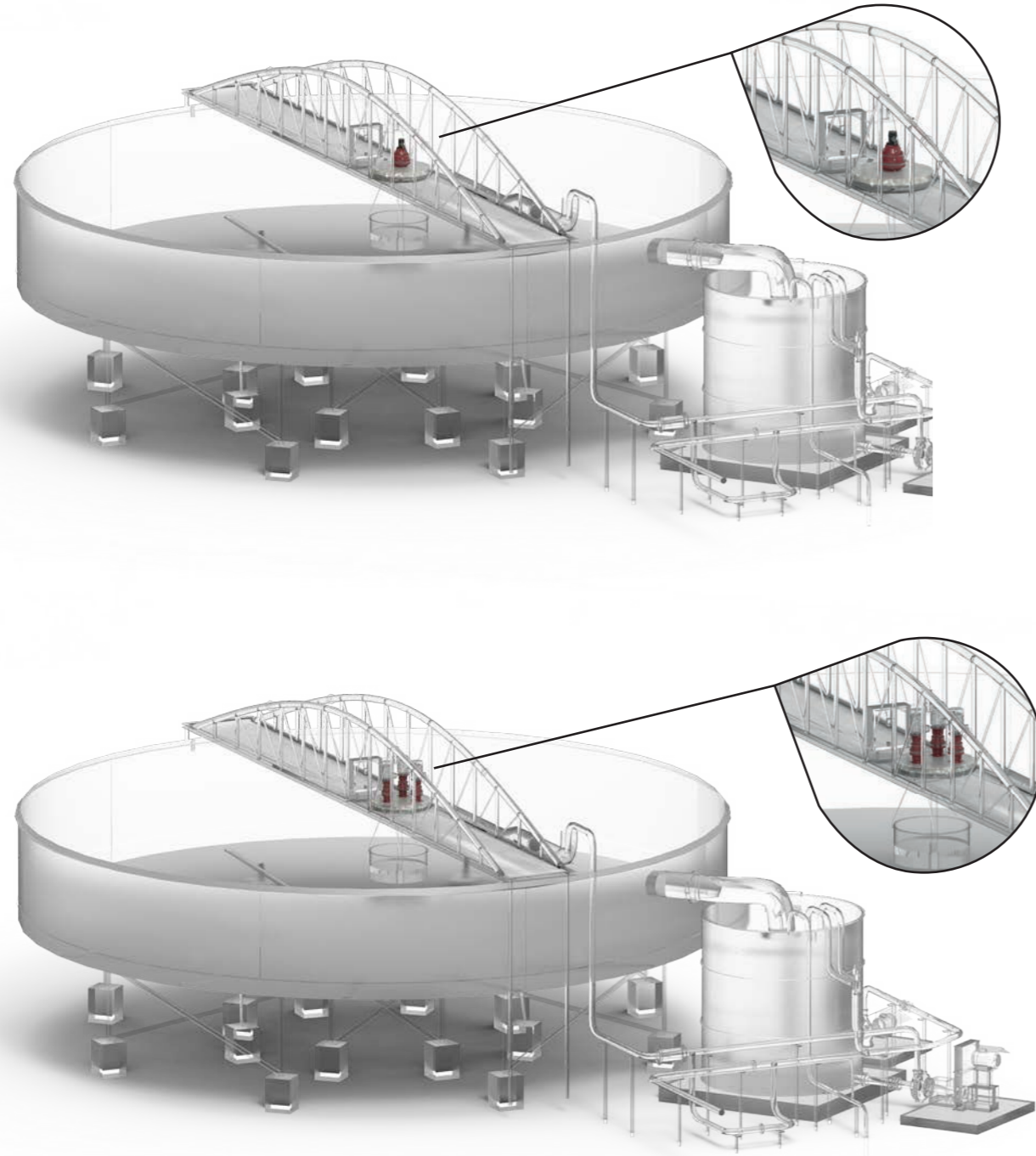

OTHER APPLICATIONS

Please contact Reggiana Riduttori Sales Department for any further information.

GLOBAL SALES NETWORK

- MASTER DISTRIBUTOR
- BRANCH



www.reggianariduttori.com

REGGIANA RIDUTTORI S.r.l.

Via Martiri di Marzabotto,7
42020 - S. Polo d'Enza (RE) - ITALY
tel. +39.0522.259111 - fax +39.0522.874321
info@reggianariduttori.com



A member of



 **REGGIANA
RIDUTTORI**
PLANETARY REDUCTION **GEARS**