

HYDRAULIC MOTORS MLHTM

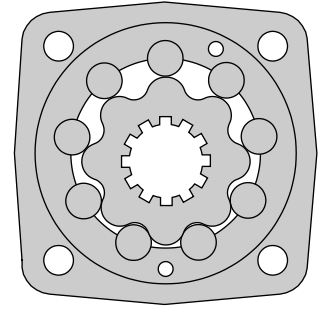

APPLICATION

- » Skid Steer Loaders
- » Metal working machines
- » Trenchers
- » Augers
- » Machines for agriculture
- » Road building machines
- » Special vehicles
- » Mine machines
- » Woodworking and sawmill machinery
- » Conveyors etc.



CONTENTS

Specification data	47
Dimensions and mounting	48+50
Shaft extensions	51
Permissible shaft seal pressure	51
Dimensions and mounting - MLHTMV	52
Dimensions of the attached component - MLHTMV	52
Dimensions and mounting - MLHTM6V	53
Dimensions of the attached component - MLHTM6V	53
Internal Spline data	54
Order code	54

OPTIONS

- » Model- Disc valve, roll-gerotor
- » Flange with wheel mount
- » Short motor
- » Side ports
- » Shafts- straight, splined and tapered
- » SAE and BSPP ports;
- » Other special features.

EXCELLENCE

- » High torque and pressure drop
- » High inlet pressure
- » High starting torque
- » Improved efficiency at high pressure drop
- » Smooth operation at low speed

GENERAL

Displacement,	in ³ /rev [cm ³ /rev.]	12.29÷44.2 [201,4÷724,3]
Max. Speed,	[RPM]	625÷170
Max. Torque,	in-lb [daNm]	6375÷15490 [72÷175]
Max. Output,	HP [kW]	37,5÷55 [28÷41]
Max. Pressure Drop,	PSI [bar]	3600÷2320 [250÷160]
Max. Oil Flow,	GPM [lpm]	33 [125]
Min. Speed,	[RPM]	5
Permissible Shaft Loads	lbs [daN]	P _a =2250 [1000]
Pressure fluid		Mineral based- HLP(DIN 51524) or HM(ISO 6743/4)
Temperature range,	°F [°C]	-22÷194 [-30÷90]
Optimal Viscosity range, SUS [mm²/s]		98÷347 [20÷75]
Filtration		ISO code 20/16 (Min. recommended fluid filtration of 25 micron)

Oil flow in drain line

Pressure drop PSI [bar]	Viscosity SUS [mm ² /s]	Oil flow in drain line GPM [lpm]
2030 [140]	98 [20]	.660 [2,5]
	164 [35]	.396 [1,5]
3045 [210]	98 [20]	1.321 [5]
	164 [35]	.793 [3]

Pressure Losses

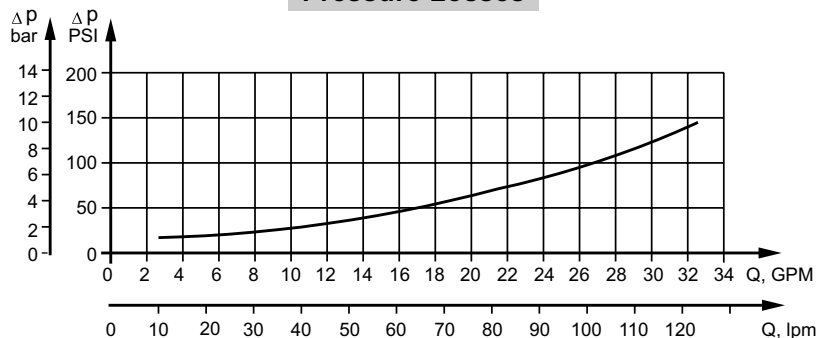

SPECIFICATION DATA

Type		MLHTM 200	MLHTM 250	MLHTM 315	MLHTM 400	MLHTM 470	MLHTM 500	MLHTM 630	MLHTM 725
Displacement, in.³/rev. [cm.³/rev.]		12.29 [201,4]	15.36 [251,8]	19.9 [326,3]	25.06 [410,9]	28.97 [475]	31.95 [523,6]	38.52 [631,2]	44.2 [724]
Max. Speed, [RPM]	Cont.	625	500	380	305	260	240	185	170
	Int.*	750	600	460	365	315	285	225	215
Max. Torque in-lb [daNm]	Cont.	6375 [72]	7965[90]	10265[116]	13010[147]	15135[171]	15225[172]	15490[175]	14160[160]
	Int.*	9030[102]	11330[128]	14425[163]	18232[206]	16030[215]	19030[215]	19030[215]	17000[192]
	Peak**	10180[115]	12745[144]	16460[186]	20800[235]	21240[240]	21240[240]	21225[250]	21240[240]
Max. Output HP [kW]	Cont.	55 [41]	55 [41]	55 [41]	55 [41]	55 [41]	50[37,5]	37,5 [28]	35 [26]
	Int.*	87 [65]	94[70]	94[70]	94[70]	74[55]	68 [51]	56 [42]	54 [40]
Max. Pressure Drop PSI [bar]	Cont.	3600[250]	3600[250]	3600[250]	3600[250]	3600[250]	3340[230]	2680[185]	2320[160]
	Int.*	5080[350]	5080[350]	5080[350]	5080[350]	4570[315]	4060[280]	3260[225]	3045[210]
	Peak**	5800[400]	5800[400]	5800[400]	5800[400]	5080[350]	4640[320]	3915[270]	3770[260]
Max. Oil Flow GPM [lpm]	Cont.	33[125]	33[125]	33[125]	33[125]	33[125]	33[125]	33[125]	33[125]
	Int.*	40[150]	40[150]	40[150]	40[150]	40[150]	40[150]	40[150]	40[150]
Max. Inlet Pressure PSI [bar]	Cont.	3920[270]	3920[270]	3920[270]	3920[270]	3920[270]	3920[270]	3920[270]	3920[270]
	Int.*	5370[370]	5370[370]	5370[370]	5370[370]	5370[370]	5370[370]	5370[370]	5370[370]
	Peak**	6100[420]	6100[420]	6100[420]	6100[420]	6100[420]	6100[420]	6100[420]	6100[420]
Max. Return Pressure without Drain Line or Max. Pressure in Drain Line, PSI [bar]	Cont. 0-100 RPM	1100 [75]	1100 [75]	1100 [75]	1100 [75]	1100 [75]	1100 [75]	1100 [75]	1100 [75]
	Cont. 100-300 RPM	580 [40]	580 [40]	580 [40]	580 [40]	580 [40]	580 [40]	580 [40]	580 [40]
	Cont. >300 RPM	290 [20]	290 [20]	290 [20]	290 [20]	290 [20]	-	-	-
	Int.* 0-max. RPM	1100 [75]	1100 [75]	1100 [75]	1100 [75]	1100 [75]	1100 [75]	1100 [75]	1100 [75]
Max. Return Pressure with Drain Line PSI [bar]	Cont.	3920[270]	3920[270]	3920[270]	3920[270]	3920[270]	3920[270]	3920[270]	3920[270]
	Int.*	5370[370]	5370[370]	5370[370]	5370[370]	5370[370]	5370[370]	5370[370]	5370[370]
	Peak**	6100[420]	6100[420]	6100[420]	6100[420]	6100[420]	6100[420]	6100[420]	6100[420]
Max. Starting Pressure with Unloaded Shaft, PSI [bar]		6	6	6	6	6	6	6	6
Min. Starting Torque in-lb [daNm]		5310[60]	6640[75]	8585[97]	10800[122]	12570[142]	12655[143]	12830[145]	13100[148]
Min. Speed***, [RPM]		5	5	5	5	5	5	5	5
Weight, lb [kg]	MLHTM	59.3[26,9]	60.2[27,3]	62[28,1]	64 [29]	65.5[29,7]	66.6[30,2]	65.5[29,7]	68.4[31]
	MLHTMW	60.4[27,4]	61.3[27,8]	63.1[28,6]	65.1[29,5]	66.6[30,2]	67.7[30,7]	66.6[30,2]	69.5[31,5]
	MLHTMV	34.6 [15,7]	35.5 [16,1]	37.3 [16,9]	39.3 [17,8]	40.8 [18,5]	41.9 [19]	40.8 [18,5]	43.7 [19,8]

* Intermittent operation: the permissible values may occur for max. 10% of every minute.

** Peak load: the permissible values may occur for max. 1% of every minute.

*** For speeds of 5 RPM lower than given, consult factory or your regional manager.

- Intermittent speed and intermittent pressure must not occur simultaneously.
- Recommended filtration is per ISO cleanliness code 20/16. A nominal filtration of 25 micron or better.
- Recommend using a premium quality, anti-wear type mineral based hydraulic oil, HLP(DIN51524) or HM(ISO6743/4). If using synthetic fluids consult the factory for alternative seal materials.
- Recommended minimum oil viscosity 70 SUS [13 cmi/s] at 122°F [50°C].
- Recommended maximum system operating temperature is 180°F [82°C].
- To assure optimum motor life fill with fluid prior to loading and run at moderate load and speed for 10-15 minutes.

DIMENSIONS -MLHTM and MLHTMC

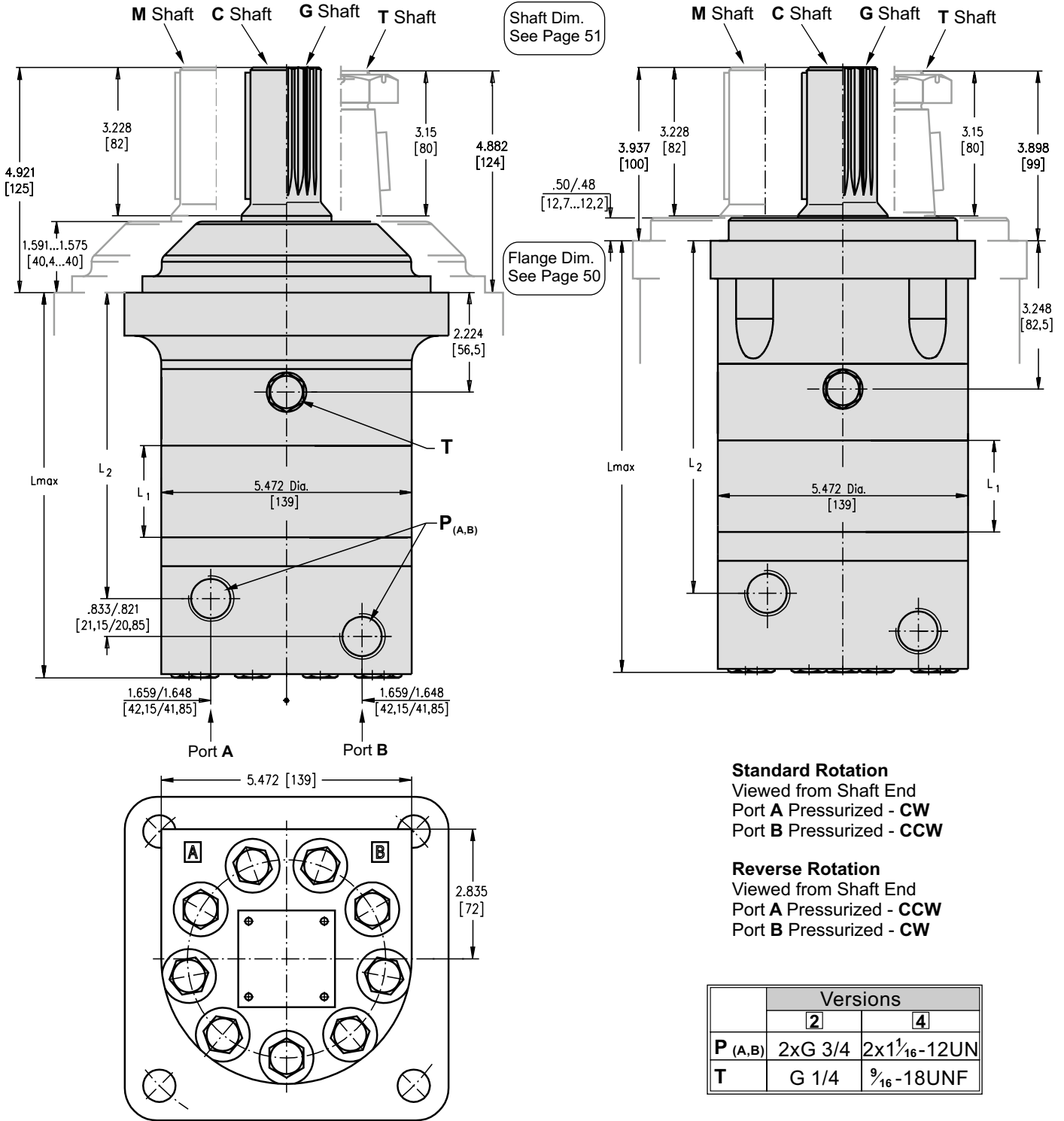

Type	L _{max} , in.[mm]	L ₂ , in.[mm]	Type	L _{max} , in.[mm]	L ₂ , in.[mm]	L ₁ , in.[mm]
MLHTM 200	7.40 [188]	5.60 [142,3]	MLHTMC 200	8.48 [215,5]	6.69 [169,8]	.98 [25]
MLHTM 250	7.64 [194]	5.85 [148,6]	MLHTMC 250	8.74 [222,0]	6.93 [176,1]	1.23 [31,3]
MLHTM 315	7.99 [203]	6.21 [157,8]	MLHTMC 315	9.09 [231,0]	7.30 [185,3]	1.59 [40,5]
MLHTM 400	8.43 [214]	6.63 [168,3]	MLHTMC 400	9.51 [241,5]	7.71 [195,8]	2.01 [51]
MLHTM 470	8.74 [222]	6.94 [176,3]	MLHTMC 470	9.82 [249,5]	8.02 [203,8]	2.32 [59]
MLHTM 500	8.98 [228]	7.18 [182,3]	MLHTMC 500	10.06 [255,5]	8.26 [209,8]	2.56 [65]
MLHTM 630	8.82 [224]	7.02 [178,3]	MLHTMC 630	9.90 [251,5]	8.10 [205,8]	2.40 [61]
MLHTM 725	9.17 [233]	7.37 [187,3]	MLHTMC 725	10.26 [260,5]	8.46 [214,8]	2.76 [70]

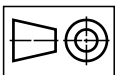

DIMENSIONS -MLHTMW

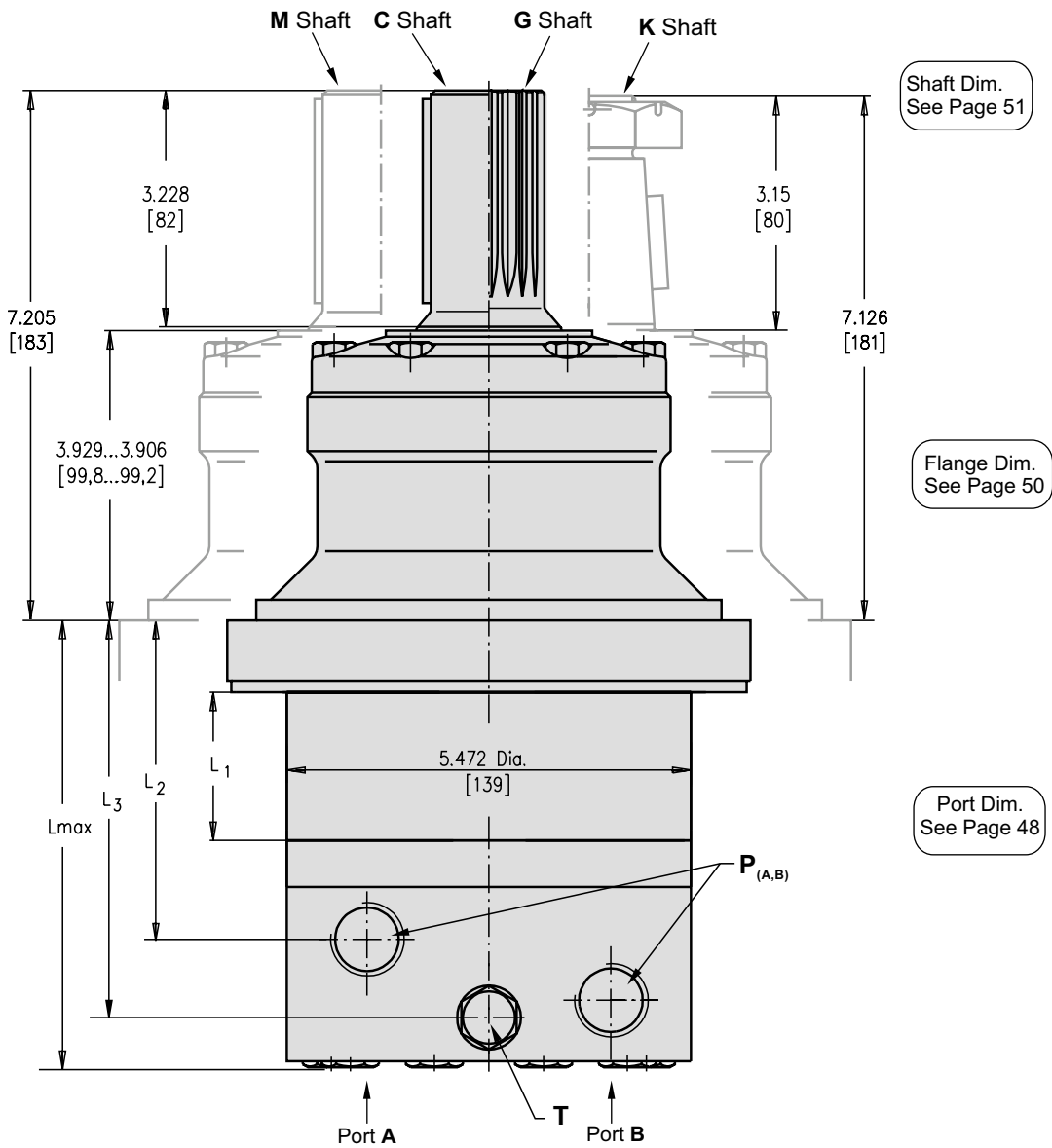

Standard Rotation
 Viewed from Shaft End
 Port A Pressurized - CW
 Port B Pressurized - CCW

Reverse Rotation
 Viewed from Shaft End
 Port A Pressurized - CCW
 Port B Pressurized - CW

Versions		
	2	4
P (A,B)	2XG 3/4	2X1 ¹ / ₁₆ -12UN
T	G 1/4	9 ¹ / ₁₆ -18UNF

Type	L _{max} , in. [mm]	L ₁ , in. [mm]	L ₂ , in. [mm]	L ₃ , in. [mm]
MLHTMW 200	5.08 [129]	.98 [25]	3.30 [83,8]	3.37 [111,1]
MLHTMW 250	5.32 [135]	1.23 [31,3]	3.55 [90,1]	4.62 [117,4]
MLHTMW 315	5.67 [144]	1.59 [40,5]	3.91 [99,3]	4.98 [126,6]
MLHTMW 400	6.10 [155]	2.01 [51]	4.32 [109,8]	5.40 [137,1]
MLHTMW 470	6.42 [163]	2.32 [59]	4.64 [117,8]	5.71 [145,1]
MLHTMW 500	6.65 [169]	2.56 [65]	4.87 [123,8]	5.95 [151,1]
MLHTMW 630	6.50 [165]	2.40 [61]	4.72 [119,8]	5.79 [147,1]
MLHTMW 725	6.85 [174]	2.76 [70]	5.07 [128,8]	6.15 [156,1]

DIMENSIONS OF MOUNTING

4-Bolt flange
spigot diameter 6.3 in. [160 mm] - BC 7.87 in. [200 mm]

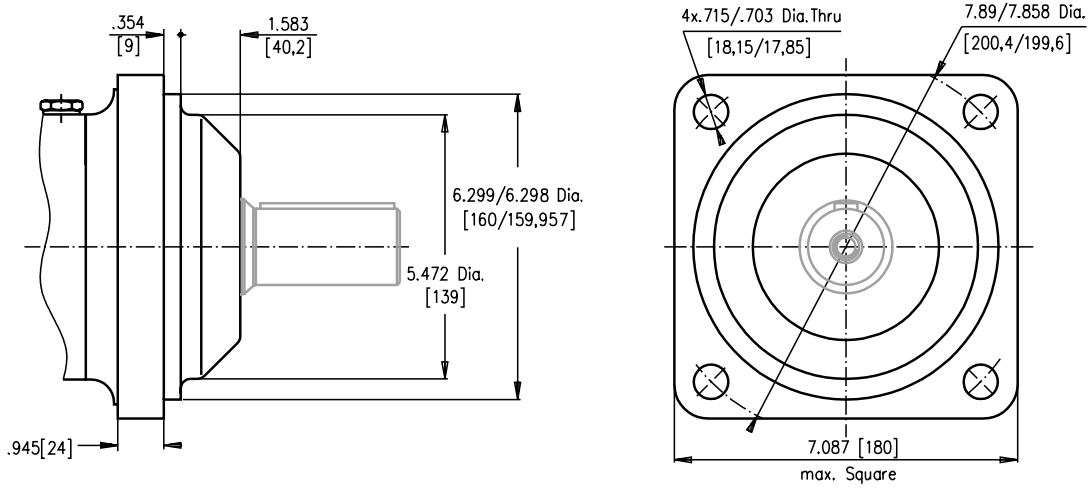

C 4-Bolt flange, SAE C mounting flange
spigot diameter 5.00 in. [127 mm]
BC 6.37 in. [161,9 mm]

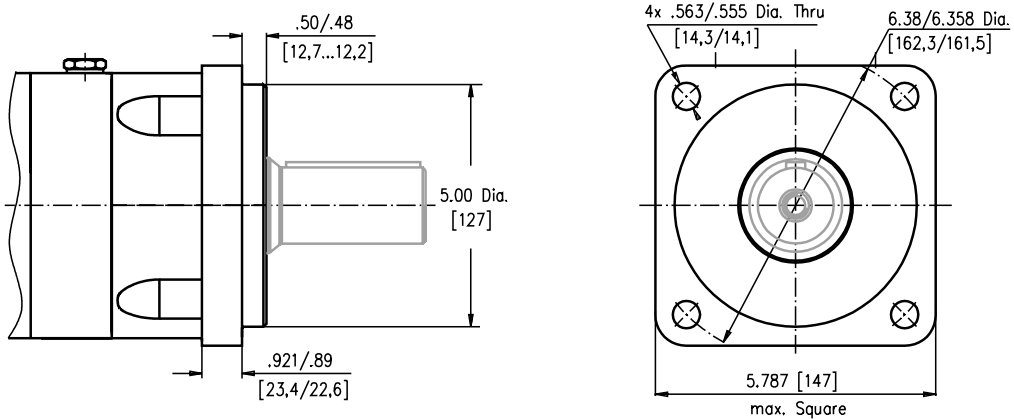

W 4-Bolt flange, Wheel Motor
spigot diameter 6.3 in. [160 mm] - BC 7.87 in. [200 mm]

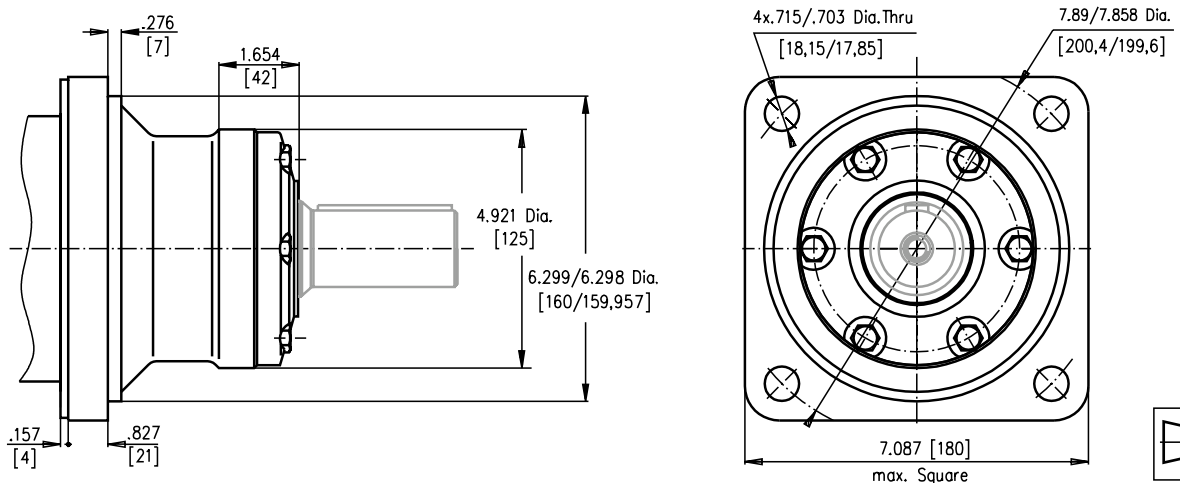

SHAFT EXTENSIONS

C

1 1/2" [38,1] sraight, Parallel key 3/8"x 3/8"x 2 1/4" BS46
Max. Torque 11750 in-lb [133 daNm]

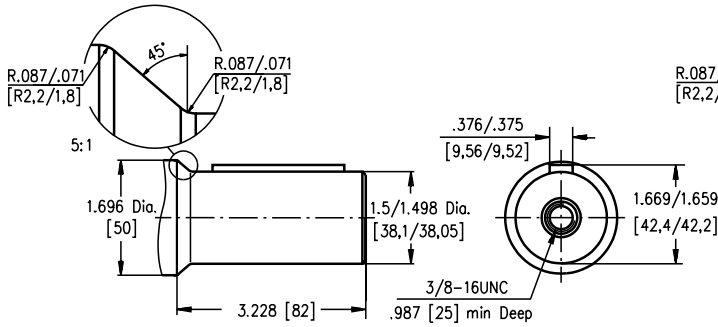

M

ø40 sraight, Parallel key A12x8x70
Max. Torque 11750 in-lb [133 daNm]

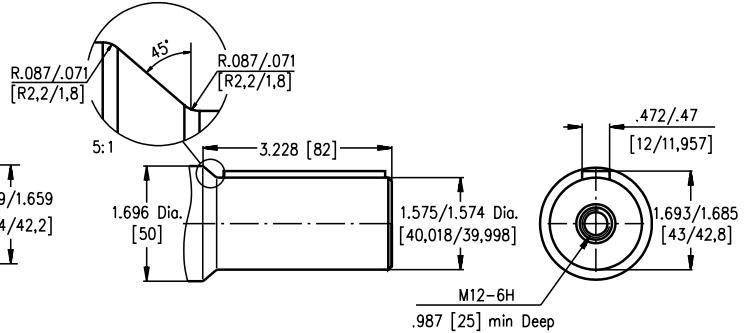

G

17T Splined, 1 1/2" [38,1] ANS B92.1-1976
Max. Torque 11750 in-lb [133 daNm]

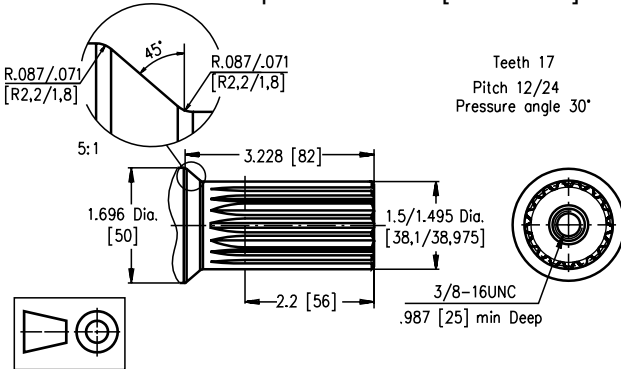

T

1 3/4" [44,5] SAE J501 Tapered 1:8
Parallel key 7/16"x 7/16"x 1 1/4" BS46
Max. Torque 18650 in-lb [210 daNm]

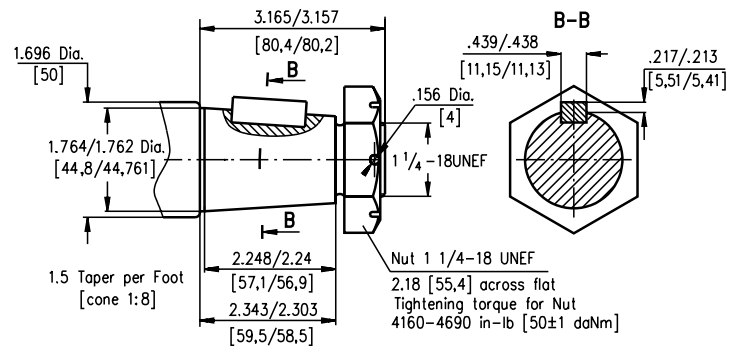

Requirement max. Torque must be not exceeded.

PERMISSIBLE SHAFT LOADS

The curves apply to a B10 bearing life (ISO281) of 2000 hours at 200 RPM.

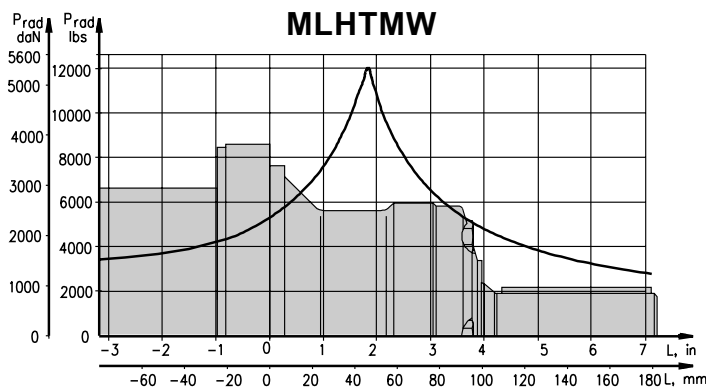
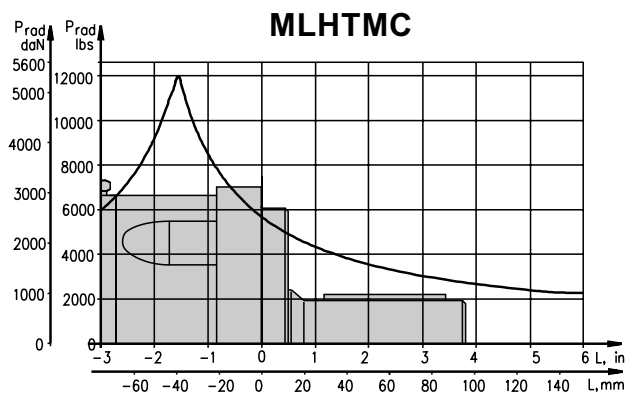
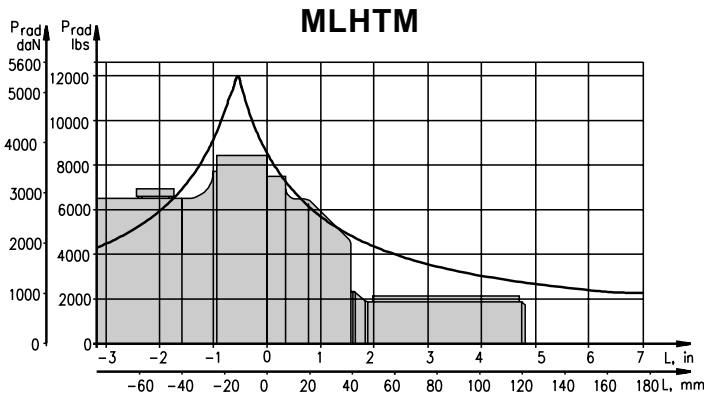

OUTLINE DIMENSIONS REFERENCE FOR MLHTMV

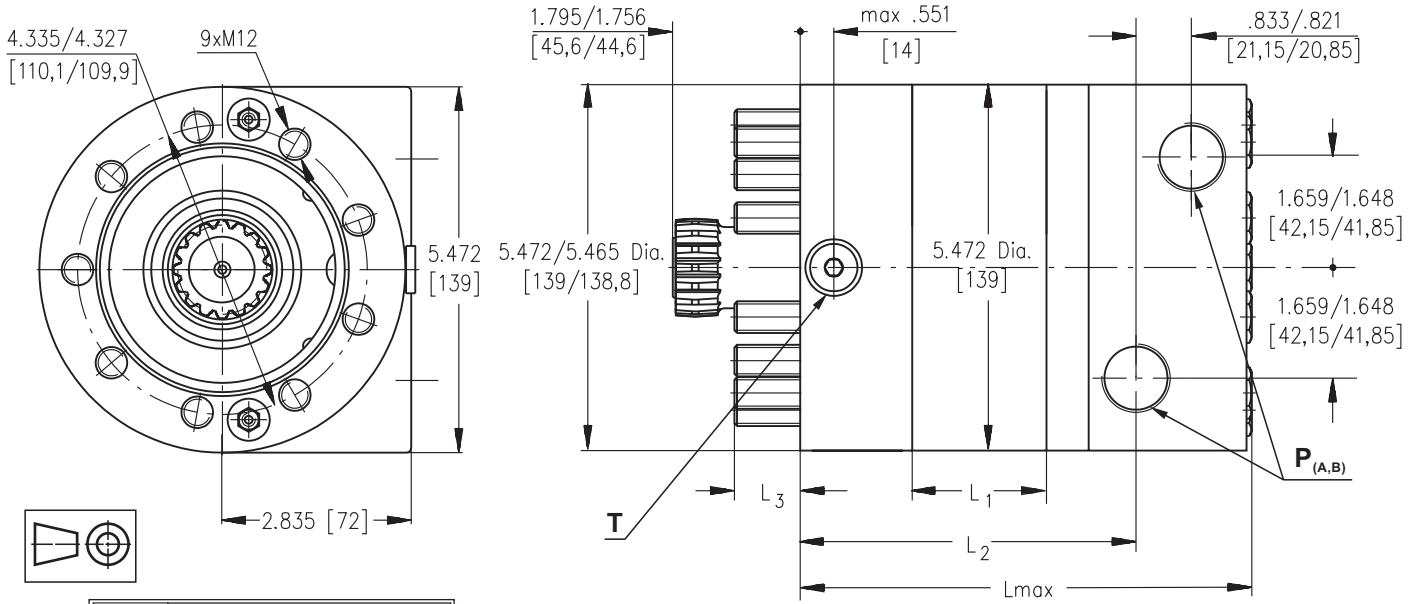

Versions		
	2	4
P (A,B)	2xG 3/4	2x1 ¹ / ₁₆ -12UN
T	G 1/4	9 ¹ / ₁₆ -18UNF

Standard Rotation
Viewed from Shaft End
Port A Pressurized - CW
Port B Pressurized - CCW

Reverse Rotation
Viewed from Shaft End
Port A Pressurized - CCW
Port B Pressurized - CW

Type	L ₁ , in.[mm]	L, in.[mm]	L ₂ , in.[mm]	L ₃ , in.[mm]
MLHTMV 200	.98 [25]	5.945 [151]	4.193 [106,5]	1.094 [27,8]
MLHTMV 250	1.23 [31,3]	6.181 [157]	4.441 [112,8]	1.043 [26,5]
MLHTMV 315	1.59 [40,5]	6.575 [167]	4.803 [122,0]	.878 [22,3]
MLHTMV 400	2.01 [51]	6.968 [177]	5.217 [132,5]	.858 [21,8]
MLHTMV 470	2.32 [59]	7.283 [185]	5.531 [140,5]	.937 [23,8]
MLHTMV 500	2.56 [65]	7.520 [191]	5.768 [146,5]	1.094 [27,8]
MLHTMV 630	2.40 [61]	7.362 [187]	5.610 [142,5]	1.055 [26,8]
MLHTMV 725	2.76 [70]	7.717 [196]	5.965 [151,5]	1.094 [27,8]

DIMENSIONS OF THE ATTACHED COMPONENT

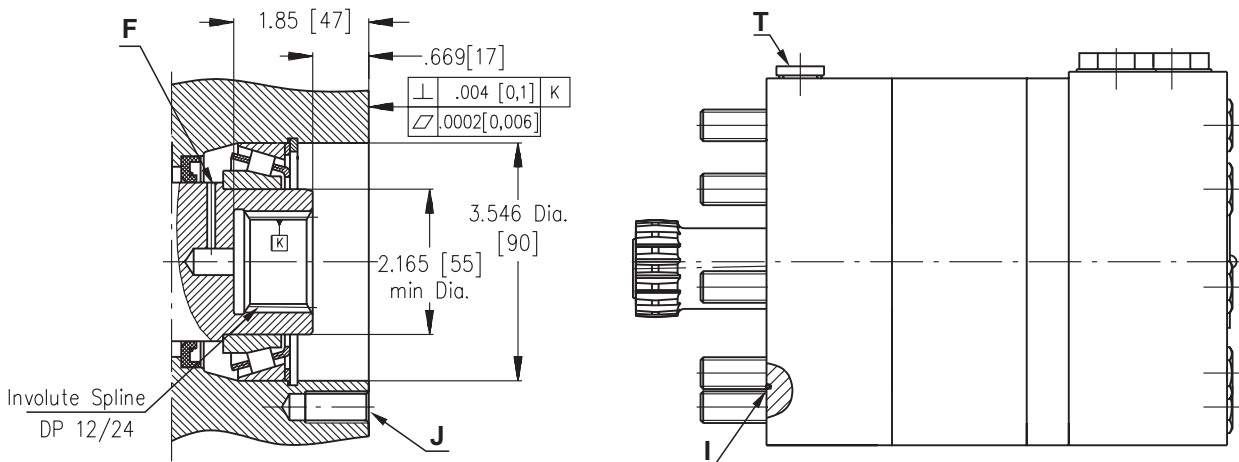

F: Oil circulation hole
J: 9xM12-1.18 [30] depth, 40°, 4.331[110] Dia. B. C.

I: O- Ring 3.661x.059 [93x1,5]
T: Drain connection G1/4 or 9/16 - 18UNF

OUTLINE DIMENSIONS REFERENCE FOR MLHTM6V

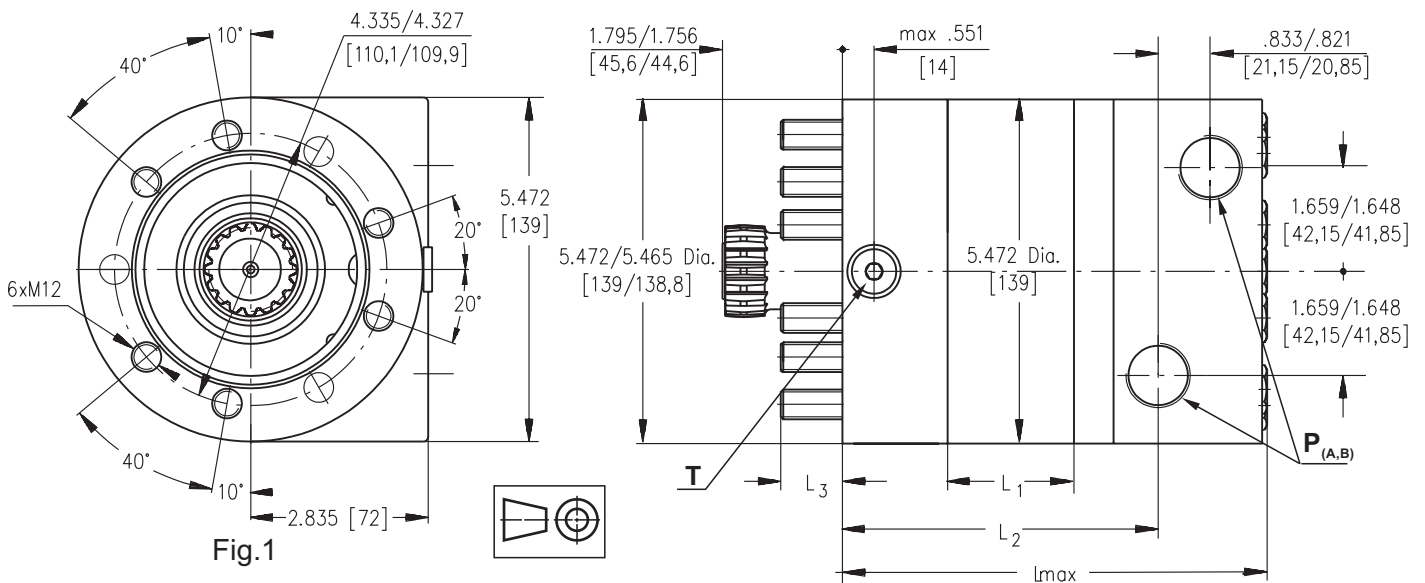

Fig.1

	Versions	
	2	4
P_(A,B)	2XG 3/4	2X1½-12UN
T	G 1/4	9/16-18UNF

Standard Rotation

Viewed from Shaft End

Port **A** Pressurized - **CW**

Port **B** Pressurized - **CCW**

Reverse Rotation

Viewed from Shaft End

Port **A** Pressurized - **CCW**

Port **B** Pressurized - **CW**

Type	L ₁ , in.[mm]	L, in.[mm]	L ₂ , in.[mm]	L ₃ , in.[mm]
MLHTM6V 200	.98 [25]	5.945 [151]	4.193 [106,5]	1.094 [27,8]
MLHTM6V 250	1.23 [31,3]	6.181 [157]	4.441 [112,8]	1.043 [26,5]
MLHTM6V 315	1.59 [40,5]	6.575 [167]	4.803 [122,0]	.878 [22,3]
MLHTM6V 400	2.01 [51]	6.968 [177]	5.217 [132,5]	.858 [21,8]
MLHTM6V 470	2.32 [59]	7.283 [185]	5.531 [140,5]	.937 [23,8]
MLHTM6V 500	2.56 [65]	7.520 [191]	5.768 [146,5]	1.094 [27,8]
MLHTM6V 630	2.40 [61]	7.362 [187]	5.610 [142,5]	1.055 [26,8]
MLHTM6V 725	2.76 [70]	7.717 [196]	5.965 [151,5]	1.094 [27,8]

DIMENSIONS OF THE ATTACHED COMPONENT

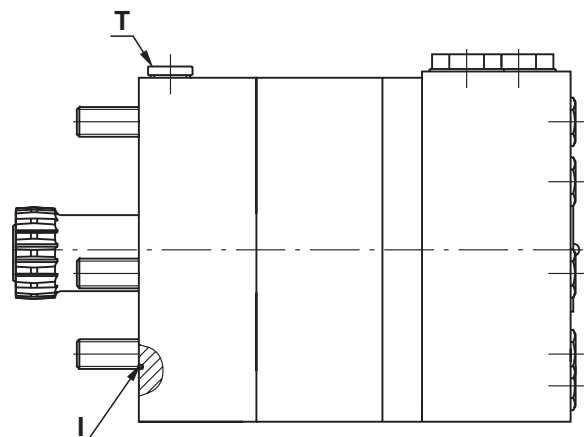
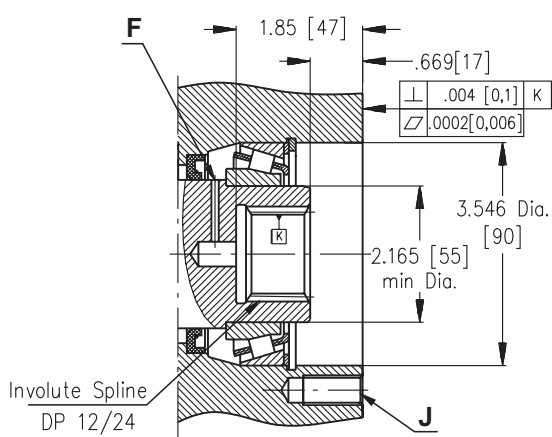

F: Oil circulation hole

J: 9xM12-1.18 [30] depth, 40°, 4.331[110] Dia. B. C.
6xM12-1.18 [30], situated in accordance with the bolts M12, shown on Fig.1, 4.331[110] Dia. B. C.

I: O- Ring 3.661x.059 [93x1,5]

T: Drain connection G1/4 or 9/16 - 18UNF

DRAIN CONNECTION

A drain line ought to be used when pressure in the return line can exceed the permissible pressure. It can be connected at the drain connection of the attached component. The maximum pressure in the drain line is limited by the attached component and its shaft seal.

The drain line must be possible for oil to flow freely between motor and attached component and must be led to the tank. The maximum pressure in the drain line is limited by the attached component and its seal.

INTERNAL SPLINE DATA FOR THE ATTACHED COMPONENT

Standard ANS B92.1-1976, class 5
[m=2.1166; corrected x.m=1]

Fillet Root Side Fit		inch	mm
Number of Teeth	z	16	16
Diametral Pitch	DP	12/24	12/24
Pressure Angle		30 ⁰	30 ⁰
Pitch Dia.	D	1.3333	33,8656
Major Dia.	D _{ri}	1.5118÷1.5275	38,4 ^{+0,4}
Minor Dia.	D _i	1.2657÷1.2673	32,15 ^{+0,04}
Circular Space Width	Lo	.1763÷.1791	4,516±0,037
Fillet Radius	R	.02	0,5
Dimension Between Two Pins	L	1.063÷1.059	26,9 ^{+0,10}
Pin Dia.	d	.19026÷.19034	4,835±0,001

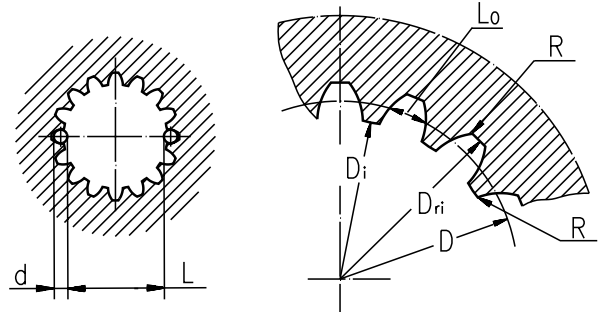

Hardening Specification:
 HV=750±50 on the surface.
 HV=560 at .035±.019 [0,7±0,2] case depth
 Material: 20 MoCr4 EN 10084 or SAE8620.

ORDER CODE

	1	2	3	4	5	6
MLHTM						

Pos.1 - Mounting Flange

- omit - 4-Bolt flange, spigot dia. 6.3in., BC 7.87 in.
- C** - SAE C, 4-Bolt flange, spigot dia. 5 in., BC 6.37 in.
- W** - Wheel motor, spigot dia. 6.3in., BC 7.87 in
- V** - Veryshort mount, 9xM12 mounting bolts
- 6V** - Veryshort mount, 6xM12 mounting bolts

Pos.2 - Displacement code [without performance data]

- 200** - 12.29 [201,4] in.³/rev. [cm.³/rev.]
- 250** - 15.36 [251,8] in.³/rev. [cm.³/rev.]
- 315** - 19.90 [326,3] in.³/rev. [cm.³/rev.]
- 400** - 25.06 [410,9] in.³/rev. [cm.³/rev.]
- 470** - 28.97 [475,0] in.³/rev. [cm.³/rev.]
- 500** - 31.95 [523,6] in.³/rev. [cm.³/rev.]
- 630** - 38.52 [631,2] in.³/rev. [cm.³/rev.]
- 725** - 44.20 [724,3] in.³/rev. [cm.³/rev.]

Pos.3 - Shaft Extensions*

- C** - 1½" [38,10] straight, Parallel key
- G** - 1½" [38,10] 17T Splined
- M** - 40 mm straight, Parallel key
- T** - 1¾" [44,50] J501 Tapered

Pos.4 - Port Size/Type [standard manifold to each]

- 2** - side ports, 2xG 3/4, G1/4, BSP thread, ISO 228
- 4** - side ports, 2xG1 1/16-12 UN, O-ring, 9/16-18 UNF

Pos.5 - Special Features [see page 65]

Pos.6 - Design Series

- omit - Factory specified

Notes: * The permissible output torque for shafts must be not exceeded!

** Color at customer's request.

The hydraulic motors are mangano phosphatized as standard.