

MOTOR SPECIAL FEATURES

Special Feature Description	Order Code	Motor type				
		MLHS	MLHSY	MLHT	MLHTM	MLHV
Motor for Speed Sensor*	RS	O	O	O	O	O
Tacho Connection**	T	O	O	O	-	O
Low Leakage	LL	O	O	O	O	O
Low Speed Valving	LSV	O	O	O	O	O
Reverse Rotation	R	O	O	O	O	O
Paint***	P	O	O	O	O	O
Corrosion Protected Paint***	PC	O	O	O	O	O
Check Valves		S	S	S	S	S

- O** Optional
- Not applicable
- S** Standard

* for sensor ordering see page 66-67.

** for side ports only.

*** color at customer's request.

MOTORS WITH SPEED SENSOR

MLHS(Y)...RS

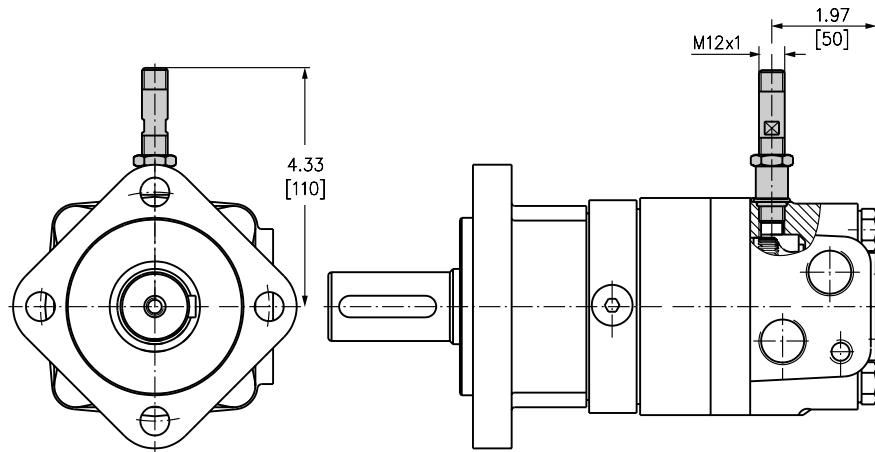

MLHT...RS

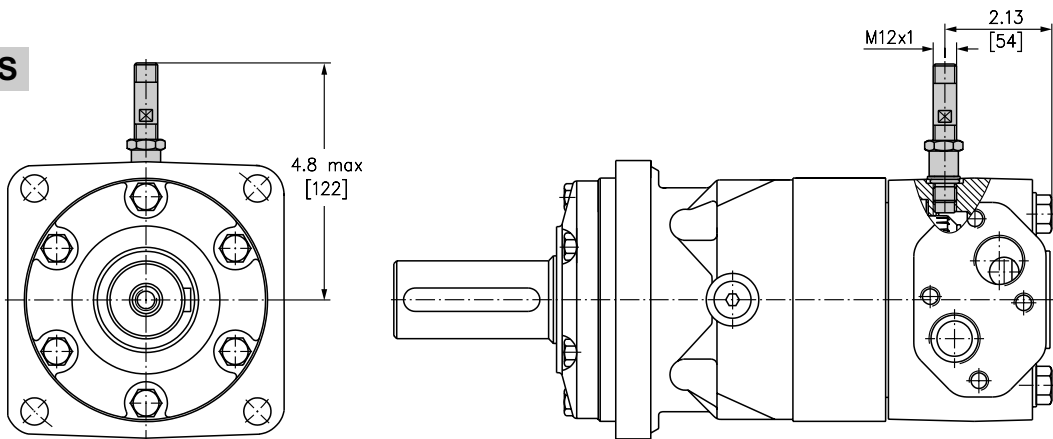

MLHTM...RS

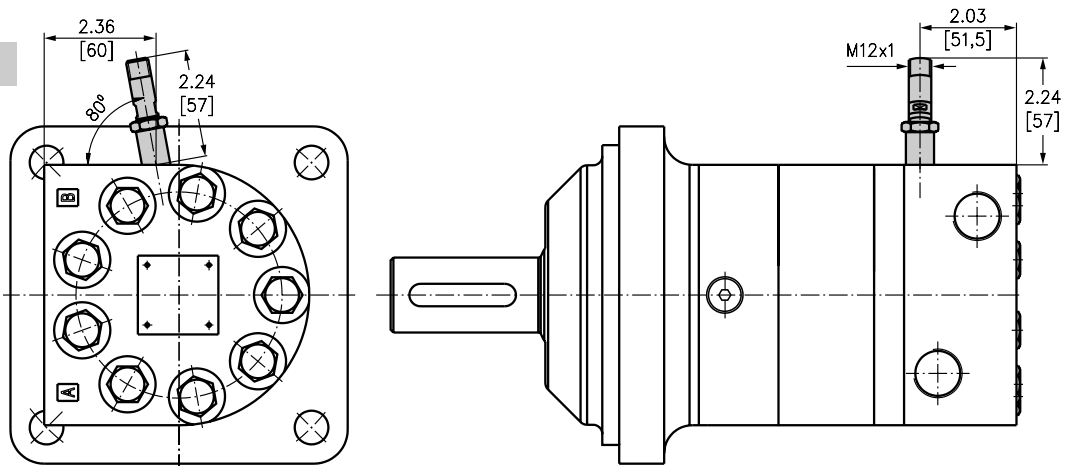

MLHV...RS

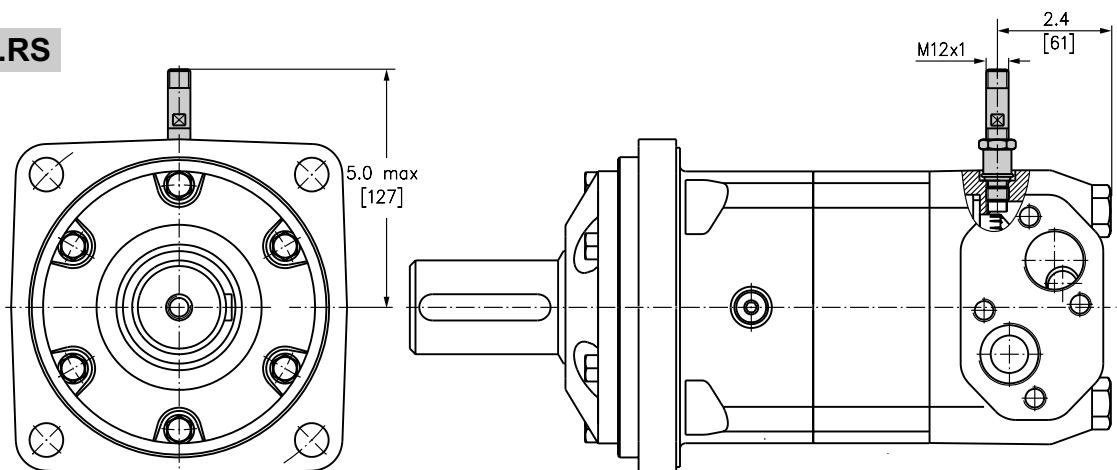

TECHNICAL DATA OF THE SPEED SENSOR

Technical data

Frequency range	0...15 000 Hz
Output	PNP, NPN
Power supply	10...36 VDC
Current input	20 mA (@24 VDC)
Ambient Temperature	-40...+257°F [-40...+125°C]
Protection	IP 67
Plug connector	M12-Series
Mounting principle	ISO 6149

Output signal

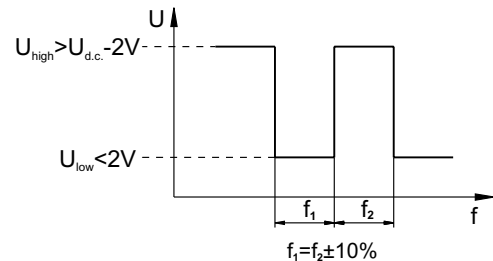

Load max.: $I_{high} = I_{low} < 50mA$

Motor type	MLHS	MLHT	MLHTM	MLHV
Pulses per revolution	54	84	84	102

Wiring diagrams

PNP

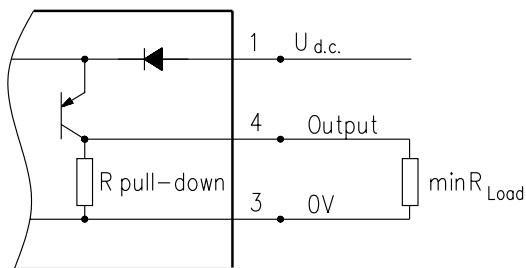

NPN

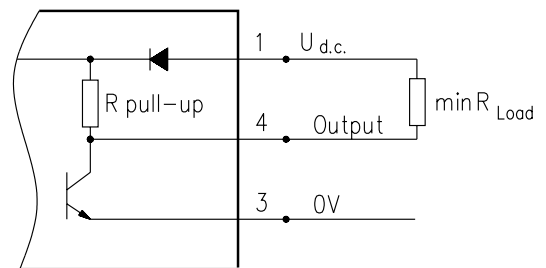

$$R_{Load} [k\Omega] = U_{d.c.} [V] / I_{max} [mA]$$

Stick type

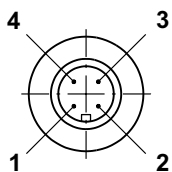

Terminal No.	Connection	Cable Output
1	$U_{d.c.}$	Brown
2	No connection	White
3	$0V$	Blue
4	Output signal	Black

Order Code for Speed Sensor

Sensor Code	Output type	Electric connection
RSN	NPN	Connector BINDER 713 series
RSP	PNP	Connector BINDER 713 series
RSNL5	NPN	Cable output 3x0,25; 196 in [5m] long
RSPL5	PNP	Cable output 3x0,25; 196 in [5m] long

NOTE: *- The speed sensor is not fitted at the factory, but is supplied in a plastic bag with the motor. For installation see enclosed instructions.

HYDRAULIC MOTORS

MOTOR APPLICATION

VEHICLE DRIVE CALCULATIONS

1. Motor speed: n, RPM

$$n = \frac{168 \times v_{ml} \times i}{R_{in}} \quad n = \frac{2,65 \times v_{km} \times i}{R_m}$$

v_{km} - vehicle speed, km/h;

v_{ml} - vehicle speed, mil/h;

R_m - wheel rolling radius, m;

R_{in} - wheel rolling radius, in;

i - gear ratio between motor and wheels.

If no gearbox, use $i=1$.

2. Rolling resistance: RR, lbs [daN]

The resistance force resulted in wheels contact with different surfaces:

$$RR = G \times \rho$$

G - total weight loaded on vehicle, lbs [daN];

ρ - rolling resistance coefficient (Table 1).

Table 1

Rolling resistance coefficient In case of rubber tire rolling on different surfaces	
Surface	ρ
Concrete- faultless	0.010
Concrete- good	0.015
Concrete- bad	0.020
Asphalt- faultless	0.012
Asphalt- good	0.017
Asphalt- bad	0.022
Macadam- faultless	0.015
Macadam- good	0.022
Macadam- bad	0.037
Snow- 5 cm	0.025
Snow- 10 cm	0.037
Polluted covering- smooth	0.025
Polluted covering- sandy	0.040
Mud	0.037÷0.150
Sand- Gravel	0.060÷0.150
Sand- loose	0.160÷0.300

3. Grade resistance: GR, lbs [daN]

$$GR = G \times (\sin \alpha + \rho \times \cos \alpha)$$

α - gradient negotiation angle (Table 2)

Table 2

Grade %	α Degrees	Grade %	α Degrees
1%	0° 35'	12%	6° 5'
2%	1° 9'	15%	8° 31'
5%	2° 51'	20%	11° 19'
6%	3° 26'	25%	14° 3'
8%	4° 35'	32%	18°
10%	5° 43'	60%	31°

4. Accelerate force: FA, lbs [daN]

Force FA necessary for acceleration from 0 to maximum speed v and time t can be calculated with a formula:

$$FA = \frac{v_{ml} \times G}{22 \times t}, \text{ [lbs]}; \quad FA = \frac{v_{km} \times G}{3,6 \times t}, \text{ [daN]}$$

FA - accelerate force, lbs [daN];

t -time, [s].

5. Tractive effort: DP, lbs [daN]

Tractive effort DP is the additional force of trailer. This value will be established as follows:

-acc.to constructor's assessment;

-as calculating forces in items 2, 3 and 4 of trailer; the calculated sum corresponds to the tractive effort requested.

6. Total tractive effort: TE, lbs [daN]

Total tractive effort TE is total effort necessary for vehicle motion; that the sum of forces calculated in items from 2 to 5 and increased with 10 % because of air resistance.

$$TE = 1,1 \times (RR + GR + FA + DP)$$

RR - force acquired to overcome the rolling resistance;

GR - force acquired to slope upwards;

FA - force acquired to accelerate (acceleration force);

DP - additional tractive effort (trailer).

7. Motor Torque moment: M, in-lb[daNm]

Necessary torque moment for every hydraulic motor:

$$M = \frac{TE \times R_{in} [R_m]}{N \times i \times \eta_M}$$

N - motor numbers;

η_M -mechanical gear efficiency (if it is available).

8. Cohesion between tire and road covering: M_w, in-lb[daNm]

$$M_w = \frac{G_w \times f \times R_{in} [R_m]}{i \times \eta_M}$$

To avoid wheel slipping, it should be observed the following condition $M_w > M$

f - frictional factor;

G_w - total weight over the wheels, lbs [daN].

Table 3

Surface	Frictional factor f
Steel on steel	0.15 ÷ 0.20
Rubber tire on polluted surface	0.5 ÷ 0.7
Rubber tire on asphalt	0.8 ÷ 1.0
Rubber tire on concrete	0.8 ÷ 1.0
Rubber tire on grass	0.4

9.Radial motor loading: P_{rad} , lbs [daN]

When motor is used for vehicle motion with wheels mounted directly on motor shaft, the total radial loading of motor shaft P_{rad} is a sum of motion force and weight force acting on one wheel.

- G_w - Weight held by wheel;
- P_{rad} - Total radial loading of motor shaft;
- M/R - Motion force.

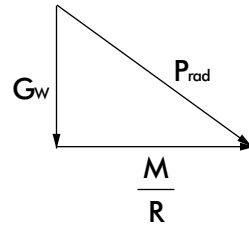

$$P_{rad} = \sqrt{G_w^2 + \left(\frac{M}{R}\right)^2}$$

In accordance with calculated loadings the suitable motor from the catalogue is selected.

DRAINAGE SPACE AND DRAINAGE PRESSURE

Advantages in oil drainage from drain space: Cleaning; Cooling and Seal lifetime prolonging.

